

**MODEL: 4031**  
Stacking Chair

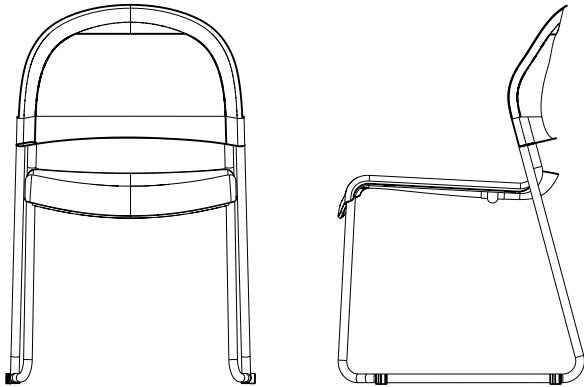

**CHAIR SPECIFICATIONS**

Max. Width.....	21
Max. Depth.....	21-1/2
Max. Height.....	31
<u>Seat Size</u>	
Width.....	18
Depth.....	19
Usable Depth.....	17-1/2
Height from Floor....	17-1/2
<u>Back Size</u>	
Width.....	20
Height.....	11
Height from Seat.....	18-1/2
<u>Stack Size</u>	
Max Height.....	28 Chairs
Max Depth.....	6 Chairs

**CONSTRUCTION**

- Glide..... Clear Polycarbonate
- Frame..... Monochromatic 3/4" round, 16 gauge steel
- Seat..... 1/8" Thick textured polymer.
- Back..... 1/8" Thick textured polymer
- Chair Weight..... 11 pounds per chair.
- Shipping Weight..... 51 pounds.
- Shipped..... Completely assembled (4 per carton)
- Shipping Size..... 22" wide x 21-1/2" deep x 35-1/2" high  
(Freight Class 125.)
- Flammability Rating..... Furnished upon request by THE HON COMPANY CUSTOMER SERVICE. This Model meets the State Of California Department of Consumer Affairs Technical Bulletin 117 requirements.
- Note..... All measurements are per ANSI/BIFMA procedures.

**Issue Date:** 06-26-95  
**Part Number:** 53-4301