

FREESTANDING TABLE

INSTALLATION INSTRUCTIONS

Illustration 1

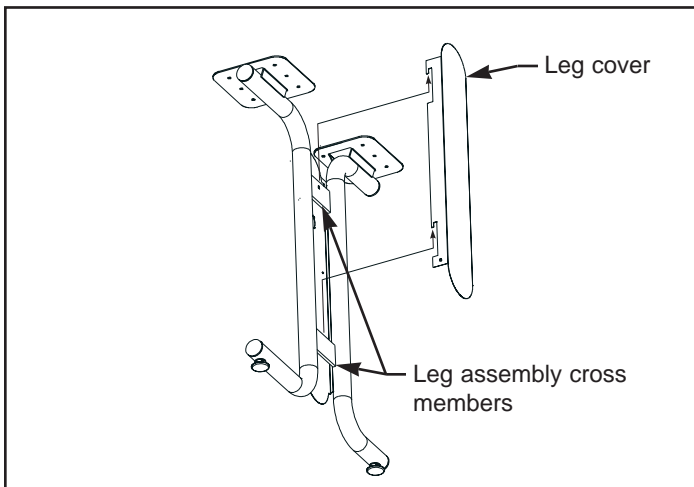

Read all instructions and review illustrations before installing.

Tools required for assembly:

1/4" power nutdriver	Drill
Phillips screwdriver	Safety glasses

This assembly includes:

(1) Table top	(1) Right leg assembly
(1) Modesty panel	(1) Left leg assembly
(4) 1/2" long screw	(4) Grommet half
(19) 7/8" long screw	

! WARNING

Sharp edges may cause injury. Take care when handling metal parts.

To prevent the possibility of serious eye injury, always wear eye protection when using power tools.

Illustration 2

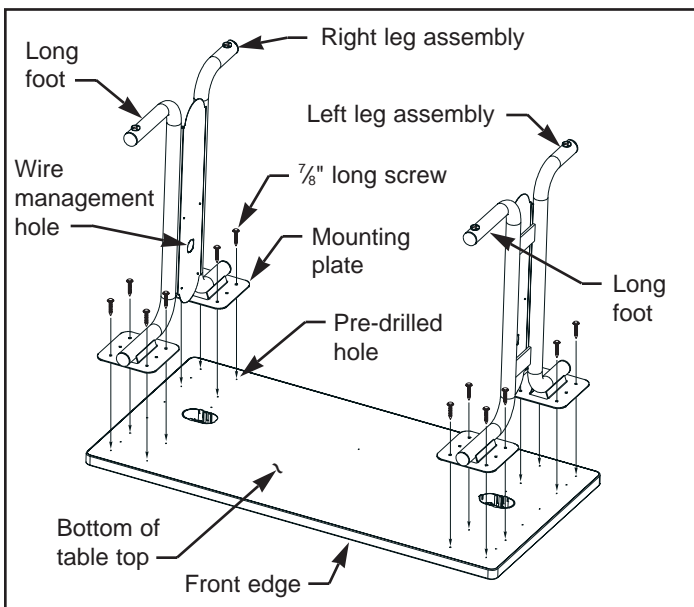
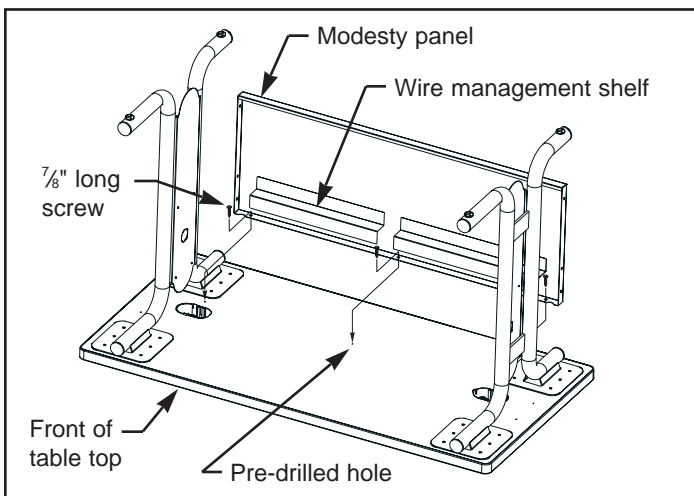

Table Assembly:

1. Refer to Illustration 1. Remove leg covers from leg assemblies. Slide leg cover toward top of leg assembly until leg cover tabs are free of leg assembly cross members. Set leg covers aside for later use.
2. Refer to Illustration 2. Use two or more people to place table top, upside down, on cardboard or a carpeted surface (this is to prevent the top from being scratched).
3. Refer to Illustration 2. With wire management holes facing each other and longer feet facing front edge of table, place leg assemblies onto table top as shown. Align holes in leg assembly mounting plates with pre-drilled holes in table top.
4. Refer to Illustration 2. Use the 1/4" power nutdriver and drill to install four 7/8" long screws (from hardware pack) through corner holes in each leg assembly mounting plate and into table top. Do not tighten screws at this time.
5. Refer to Illustration 3. With wire management shelf facing the front edge of table top, position modesty panel along rear edge of table top as shown.
6. Refer to Illustration 3. Align holes along top edge of modesty panel with pre-drilled holes in table top.
7. Refer to Illustration 3. Use the 1/4" power nutdriver and drill to install three 7/8" long screws (from hardware pack) through holes along top edge of modesty panel and into table top. Do not tighten screws at this time.

Illustration 3



FREESTANDING TABLE

Illustration 4

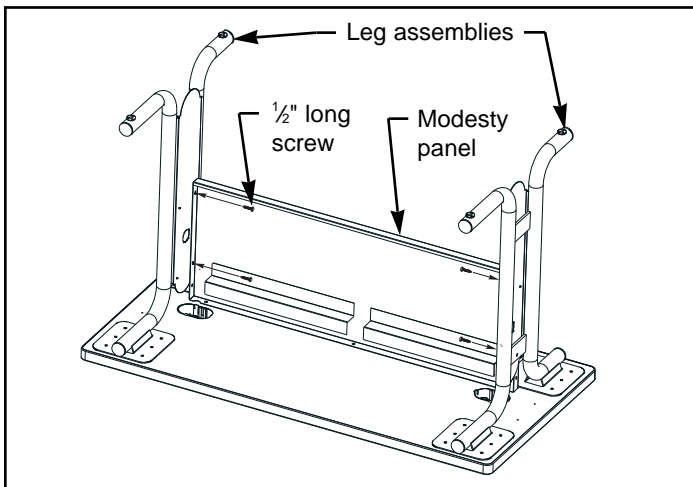

Illustration 5

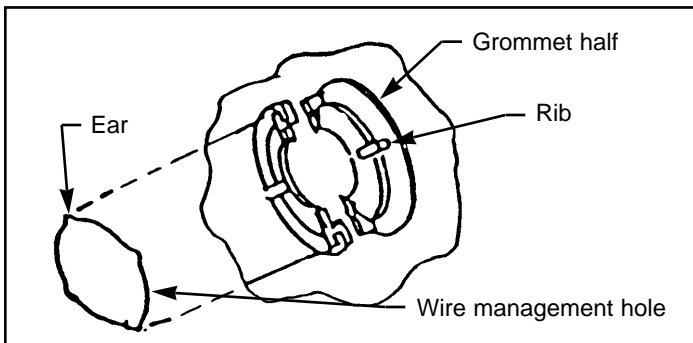
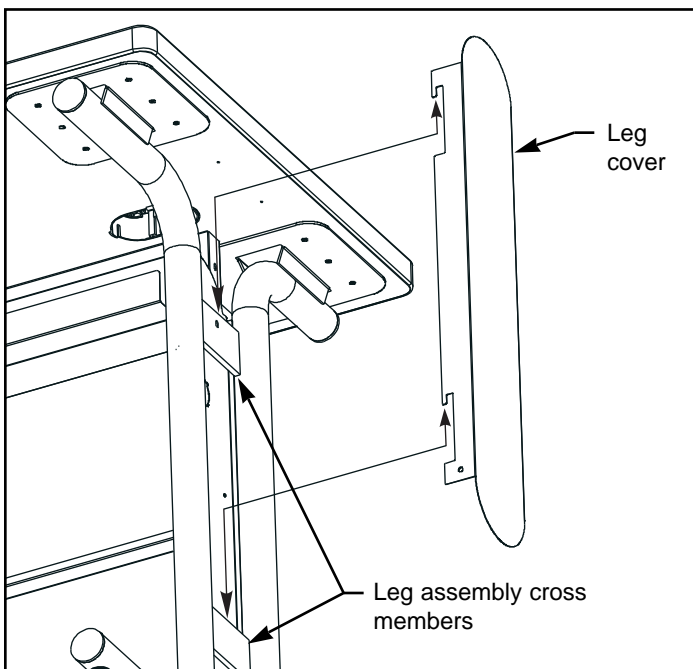

Illustration 6



8. Refer to Illustration 4. Align holes along side edges of modesty panel with holes in leg assemblies.
9. Refer to Illustration 4. Use the Phillips screwdriver to install four 1/2" long screws (from hardware pack) through holes along each side edge of modesty panel and into holes in leg assemblies.
10. Fully tighten all screws.
11. Use two or more people to set table upright.

Positioning Table:

1. Use two or more people to position table into the location the table will be used.
2. Adjust leg levelers to level table (side-to-side and front-to-back).
3. Refer to Illustration 5. Install wire management grommets (from hardware pack) onto each leg assembly. Place "rib" of each grommet half into wire management hole "ears". Twist whole grommet 1/4 turn or 45° to lock in place.
4. Reinstall leg covers (removed in Step 1) onto leg assemblies by hooking leg cover tabs over leg assembly cross members.

NOTE

If installing a hutch and hanging pedestal(s) onto this table, install the hutch before installing the hanging pedestal(s).

Wire Management:

1. Rout cabling through wire management holes, on table work surface, as needed.
2. Refer to Illustration 6. Lift leg covers straight up until leg cover tabs are free of leg assembly cross members and set leg covers aside.
3. Feed cables through a wire management grommet in each leg assembly.
4. Refer to Illustration 6. Reinstall leg covers onto leg assemblies (over cabling) by hooking leg cover tabs over leg assembly cross members.