

# MOBILE TABLE

# INSTALLATION INSTRUCTIONS

Illustration 1

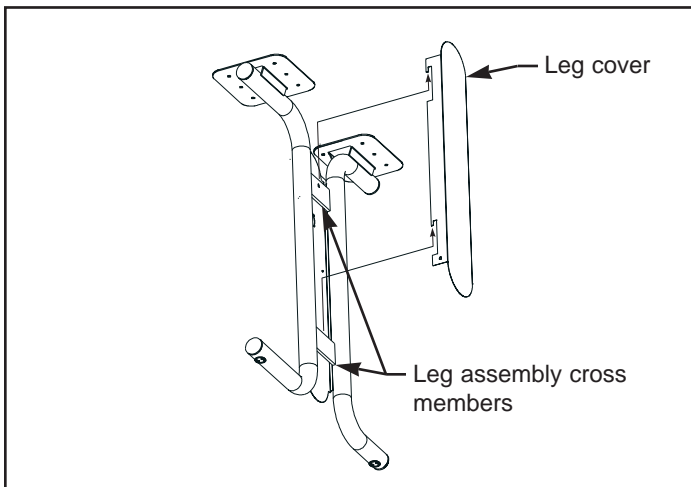

Read all instructions and review illustrations before installing.

Tools required for assembly:

1/4" power nutdriver	1/2" wrench
Safety glasses	Drill
Phillips screwdriver	

This assembly includes:

(1) Table top	(1) Right leg assembly
(4) Caster	(1) Left leg assembly
(1) Modesty panel	(4) Grommet half
(4) 1/2" long screw	(19) 7/8" long screw

## WARNING

Sharp edges may cause injury. Take care when handling metal parts.

To prevent the possibility of serious eye injury, always wear eye protection when using power tools.

Illustration 2

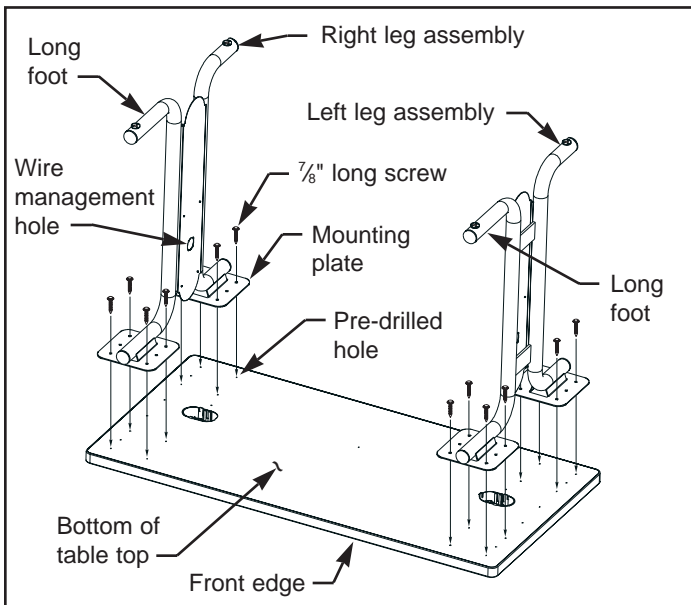

### Table Assembly:

1. Refer to Illustration 1. Remove leg covers from leg assemblies. Slide leg cover toward top of leg assembly until leg cover tabs are free of leg assembly cross members. Set leg covers aside for later use.
2. Refer to Illustration 2. Use two or more people to place table top, upside down, on cardboard or a carpeted surface (this is to prevent the top from being scratched).
3. Refer to Illustration 2. With wire management holes facing each other and longer feet facing front edge of table, place leg assemblies onto table top as shown. Align holes in leg assembly mounting plates with pre-drilled holes in table top.
4. Refer to Illustration 2. Use the 1/4" power nutdriver and drill to install four 7/8" long screws (from hardware pack) through corner holes in each leg assembly mounting plate and into table top. Do not tighten screws at this time.
5. Refer to Illustration 3. With wire management shelf facing the front edge of table top, position modesty panel along rear edge of table top as shown.
6. Refer to Illustration 3. Align holes along top edge of modesty panel with pre-drilled holes in table top.
7. Refer to Illustration 3. Use the 1/4" power nutdriver and drill to install three 7/8" long screws (from hardware pack) through holes along top edge of modesty panel and into table top. Do not tighten screws at this time.

Illustration 3

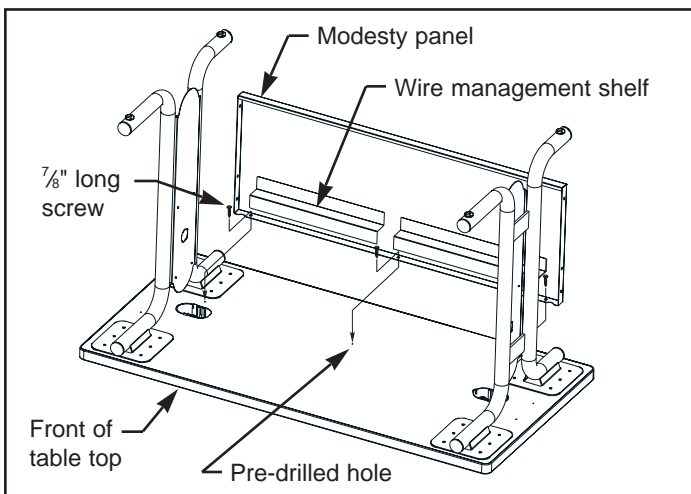

# MOBILE TABLE

**Illustration 4**

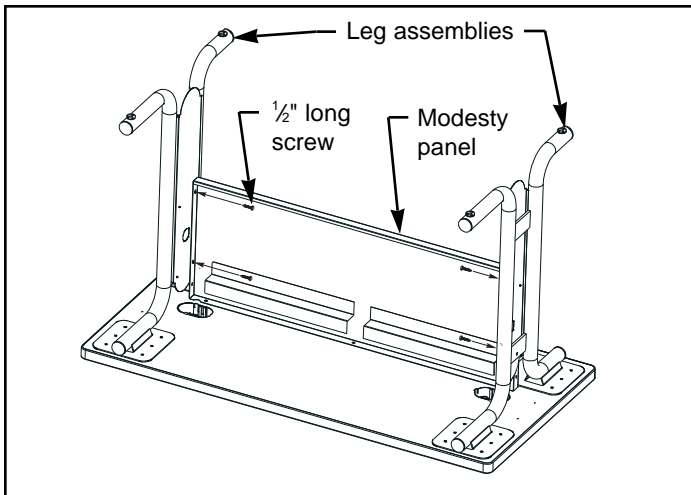

**Illustration 5**

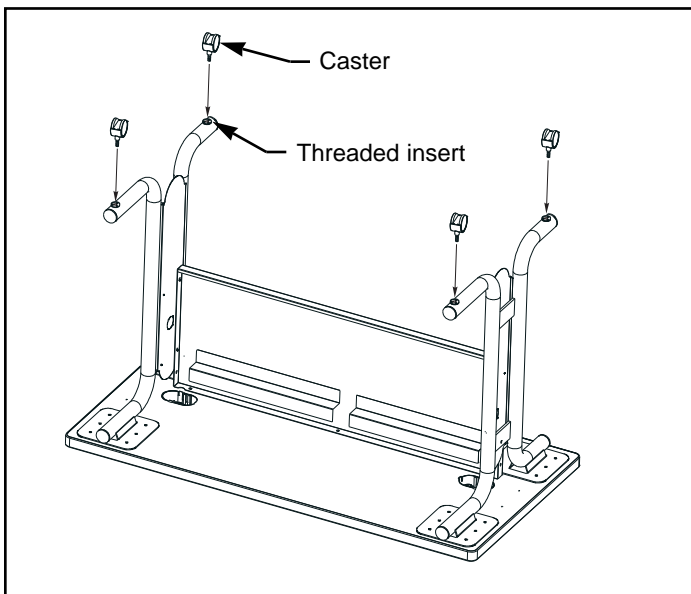

**Illustration 6**

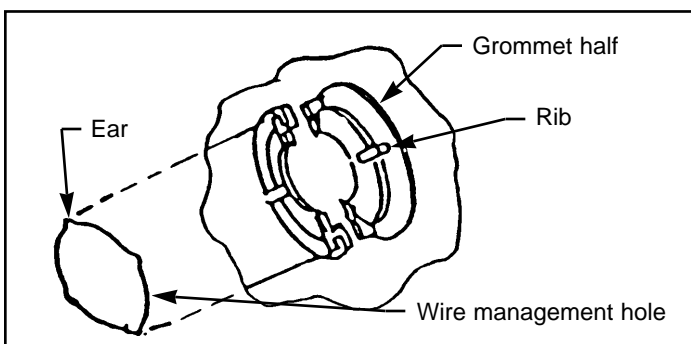

8. Refer to Illustration 4. Align holes along side edges of modesty panel with holes in leg assemblies.
9. Refer to Illustration 4. Use the Phillips screwdriver to install four 1/2" long screws (from hardware pack) through holes along each side edge of modesty panel and into holes in leg assemblies.
10. Fully tighten all screws.
11. Refer to Illustration 5. Locate four threaded inserts on bottom of leg assemblies. Thread four casters (from hardware pack) into threaded inserts by turning casters clockwise until casters are flat against leg assemblies.
12. Use the 1/2" wrench to fully tighten casters.
13. Use two or more people to set table upright.

**Positioning Table:**

1. Position table into the location the table will be used.
2. Refer to Illustration 6. Install wire management grommets (from hardware pack) onto each leg assembly. Place "rib" of each grommet half into wire management hole "ears". Twist whole grommet 1/8 turn or 45° to lock in place.
3. Refer to Illustration 6. Install leg covers onto leg assemblies by hooking leg cover tabs over leg assembly cross members.

**NOTE**

If installing a hutch and hanging pedestal(s) onto this table, install the hutch before installing the hanging pedestal(s).

**Wire Management:**

1. Rout cabling through wire management holes, on table work surface, as needed.
2. Refer to Illustration 1. Lift leg covers straight up until leg cover tabs are free of leg assembly cross members and set leg covers aside.
3. Feed cables through a wire management grommet in each leg assembly.
4. Refer to Illustration 1. Reinstall leg covers onto leg assemblies (over cabling) by hooking leg cover tabs over leg assembly cross members.