

ULTIMA 65 OPERATING INSTRUCTIONS

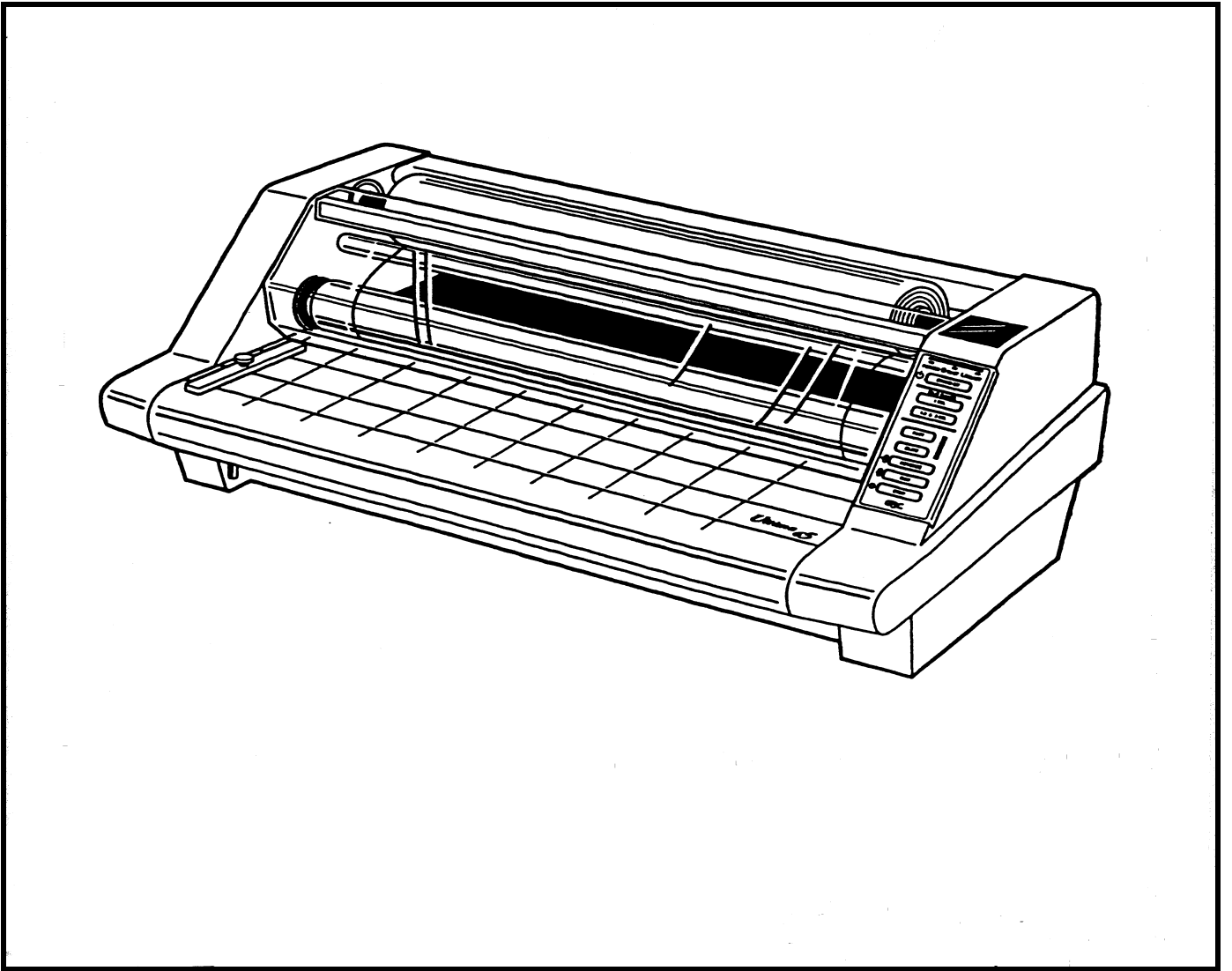

INSTALLATION

1. **Shipping damage should be brought to the immediate attention of the delivering carrier.**
2. Place the GBC Ultima 65 on a stable flat surface capable of supporting at least 95 lb. (45 kg). The surface should be at least 30 inches high to assure comfortable positioning during operation. All four rubber support feet should be positioned completely on the supporting surface. The supporting surface may also be large enough to hold the material to be laminated.
3. The laminator should be positioned to allow exiting film to drop freely to the floor. Accumulation of laminate immediately behind the laminator as it exits the equipment may cause the film to wrap around the pull rollers, resulting in a "jammed" condition.
4. Avoid locating the laminator near sources of heat or cold. Avoid locating the laminator in the direct path of forced heated or cooled air.
5. Connect the attachment plug provided with the laminator to a suitably grounded outlet only. **Avoid connecting other equipment to the same branch circuit to which the laminator is connected as this may result in nuisance tripping of circuit breakers or fuses.**

SPECIFICATIONS

Operating Speed - 1.5 fpm (45.6 cm) to 10 fpm (3m).

Dimensions - 32.5 in. (83 cm) wide x 21 in. (53 cm) long x 12 in. (31 cm) high.

Weight - 85 lb. (39 kg).

Electrical requirements - Refer to the serial plate located on the rear of the laminator for the specific electrical rating applicable to the unit.

Voltage	120V ~ 60Hz	230 ~ 50 Hz
Current	12.5A	7.8 A
Power	1500 W	1800 W

KNOW YOUR GBC ULTIMA 65 LAMINATOR

A. POWER SWITCH: Located at the back right of the machine applies power to the laminator. The "POWER" lamp will illuminate when position marked "I" is pushed. The off position marked "O" removes power from the laminator (Figure 1).

B. CONTROL PANEL: Figure 2

POWER LAMP: Indicates that the laminator is plugged in and the main power switch is in the "ON" (I) position.

 **WAIT LAMP:** Illuminates when you first turn the laminator on and when the temperature of the heat rollers is insufficient for the selected film gauge setting.

 **READY LAMP:** Indicates when the laminator has sufficient heat for the selected film

 **STANDBY BUTTON:** This button illuminates when the laminator goes into the "STANDBY" mode, reducing the temperature. When pressed, it enables the unit to return to the predetermined film gauge setting.

1 MIL BUTTON: Selects the heat and speed settings for this gauge film. The laminator automatically defaults to this setting whenever the power switch is activated.

Ultima Film (1 Mil) can be identified by a red stripe in the cardboard core.

1.5 3 MIL BUTTON: This button must be pressed to set temperature and speed settings required for these thicker gauge films.

FAST: When pressed this button increases the speed of the laminator overriding the preset condition.

SLOW: When pressed this button decreases the speed of the laminator overriding the preset condition.

 **REVERSE:** Reverses roller movement to clear jams and wrap-ups.

 **RUN:** Activates rollers for normal operation.

 **STOP:** Stops the movement of the rollers.

C. SAFETY SHIELD: Figure 3. Prevents entanglement, entrapment and inadvertent contact with the heat rollers. **The laminator will operate only when the Safety Shield is located in the fully down position. Power to the motor is removed when the shield is raised.**

D. FEED TABLE: Figure 3. The Feed Table is used to position items for lamination. **The laminator will operate only when the Feed Table and Feed Table Latch are properly installed.**

E. TABLE INTERLOCK LATCH: Figure 3. Used to lock the Feed Table into position and activate an interlock switch. The interlock latch is located on the left underside of the Feed Table. The table cannot be removed without retracting the latch to the right while lifting the table upwards and away from the laminator. **The laminator will not operate when the table is removed and/or the interlock latch is retracted.**

F. FEED GUIDE: Figure 3. The Feed Guide permits aligning the item(s) to be laminated and is used to keep longer items straight. The Feed Guide may also be used to feed smaller items side by side by positioning the guide towards the center of the Feed Table and placing smaller items against each side of the Feed Guide as they are being introduced into the nip point of the heat rollers. To position the adjustable guide, loosen the knob on the top of the guide, slide it to the desired position and tighten the knob to secure in place.

G. HEAT ROLLERS: Silicone rubber coated steel tubes. Used to heat the laminating film and compress the heated film to the items being laminated. Heat is provided by an internal infrared element. The heat rollers are motor driven for ease of loading new film.

H. IDLER BAR: The idler bars, located near each supply roll are, used to direct the film to the heat rollers. The bottom Idler Bar is movable to ease film loading.

I. PULL ROLLERS: The pull rollers, located at the back of the laminator, are motor driven. They simultaneously pull the film and improve the quality of the laminated item.

J. REAR SLITTER: Used to cut the film web where it exits the rear of the laminator (Figure 1).

K. CIRCUIT BREAKER: Electrical safety device, located under the left side cover, can be reset the operator if tripped (Figure 1).



WARNING: If the breaker trips a second time after being reset, contact GBC national Service or your dealer/distributor for assistance.

L. CORE ADAPTERS: The film shaft holds the supply roll and the adapters with locking collars hold the rolls of film on the shaft, (Figure 4).

M. FILM WEB: Laminating film loaded into the machine.



N. NIP POINT: The point at which the top and bottom rollers come into contact. The Nip Point of the heat rollers is the place at which the items for lamination are introduced into the laminator.

OPERATING INSTRUCTIONS

1. Turn the laminator on (I) at the main power switch located at the back of the machine (Figure 1).





2. CAUTION: Make sure safety shield and feed tray are in the proper position to operate the unit.

3. The laminator will automatically default to the 1.0 MIL setting. If you are using 1.5 or 3.0 MIL film you must manually press the **1.5 3.0 MIL** button. The laminator will set the speed and temperature for the respective film and 20 lb. bond paper (copier paper). If you are laminating heavier stock press **SLOW** to reduce the speed for a quality lamination. If the item is lighter increase the speed by pressing **FAST**. Adjusting the speed control to too high a speed may cause the **WAIT**  lamp to illuminate. You will have to slow the laminator down in order to ensure proper lamination. Refer to the speed Guide Chart, located on the top right side cover or section **SPEED GUIDE AND THE ART OF LAMINATING**, for speed settings on similar material.
4. **Do not begin laminating until the WAIT  lamp goes out and the READY lamp illuminates.** The normal warm-up time is approximately 10 minutes.
5. Position the item(s) to be laminated on the Feed Table.
6. Press **RUN**. The rollers will begin to turn, wait for the heat line to disappear then push the item(s) into the nip point of the heat rollers. Additional items can be laminated without stopping and starting the laminator.
7. Should a jam (wrap up) occur, press **STOP**. Refer to the section **CLEARING A FILM JAM** for specific instructions.
8. Stop the laminator once all of the laminated items completely exit the rear of the machine.



CAUTION:  **Do not reach over the laminator to operate the film cutter.**

9. The Film Cutter may be used to separate the laminated items from the film web. Position the cutter on either side of the laminator, depress the cutter's handle while sliding the cutter across the film web.
10. Allow the laminator to remain powered if it is anticipated that the machine will be used within a short period of

time. If the laminator is left for more than 90 minutes without being used the **STANDBY** button will illuminate. After an additional 30 minutes of non-use the laminator will shut off completely. The **POWER** and **STANDBY**  lamps will remain illuminated. **To reset the unit press the STANDBY  button.**

The attached power cord can be disconnected from the receptacle when the laminator will not be used for long periods of time.

FEED TABLE REMOVAL

Refer to Figure 3 and follow the procedures to remove the feed table:

1. Lift the safety shield to its full upright position.
2. Slide the Feed Table latch to the right.
3. Lift the table upwards and away from the laminator.

FILM LOADING & THREADING

Refer to Figure 5 or the film threading diagram on the feed table of the laminator for illustration of properly loaded film.

The top and bottom rolls of laminating film must be of the same width and be present simultaneously. A small amount of adhesive will "squeeze out" during lamination. Hardened adhesive deposits can damage the heat rollers. To avoid any damage rotate the rollers at slowest speed when the **WAIT**  lamp is on. Refer to the section **CARING FOR THE ULTIMA 65 LAMINATOR** for instructions regarding removal of the accumulated adhesive.

Adhesive will deposit on the rollers if:

- Only one roll is used.
- Different widths of rolls are loaded together.
- Either roll is loaded adhesive side against a heat roller.
- One or both rolls of film are allowed to run completely off the cores.

The adhesive side of the film is on the inner side of the web (Figure 5). The shiny side of clear film must contact the heat rollers. The dull side of the film contains the adhesive. Use extreme caution when loading delustered (matte) film as both sides appear dull.

Always change the top and bottom supply rolls at the same time. Near the end of each roll of GBC laminating film is a label stating "Warning-End of Roll." The appearance of this label on either the top or bottom roll requires that new rolls of film be installed as soon as the item presently being laminated completely exits the laminator. Do not introduce any additional items into the laminator when the warning label is visible.

Method Using Film Threading Card

The following procedure uses the film threading card provided with new rolls of GBC film. The laminator should be cool to the touch before proceeding.

1. Turn the main power switch on. If the laminator is already hot turn the main power switch off (O) and allow the unit to cool, then turn the machine back on (I). Remove feed table.
2. Cut remaining top and bottom film webs between supply rolls and heat rollers. **Be careful not to cut the heat rollers.**

3. Raise the safety shield to its full upright position, pull the top piece of film down.
4. Do not allow remaining film to pass through the laminator if there is any exposed liquefied or tacky adhesive. **Liquefied or tacky adhesive will deposit on the heat rollers if the following procedure is not observed.** Grab hold of the web, top and bottom film, install the feed table under the web. Lower the safety shield and push **SLOW** to speed 3 or less. Push the **Reverse** [↩] and guide the web out the front of the laminator. Make certain no exposed adhesive contacts the heat rollers and the film completely exits the laminator.
5. Press **STOP** [⏹] after the sheets have passed through the laminator.
6. Lift the safety shield to the full upright position and remove the feed table.
7. Remove the bottom roll of film by sliding the shaft to the right to release it from the hex shaped brake hub. Loosen locking screw on left retaining collar of film supply shaft, slide collar off. Pull shaft partially out of film tube then push back in to knock out left core adapter. Pull shaft all the way out and rotate tube 180 degrees. Use shaft to knock out remaining core adapter.
8. Slide one core adapter into right side of new roll of film ensuring that the film will unroll properly (from the bottom). Slide the film shaft into the core adapter and tube from the right side. Place the other core adapter on the shaft protruding from the left side then replace retaining collar. Tighten locking screw.
9. Lower the bottom idle bar, (Figure 6).
10. Unroll 2 ft. (61 cm) of film. Push leading edge under and around bottom idler bar. Slide the idler bar back into place and drape film over bottom film roll, (Figure 7). Place the bottom roll of film back on the laminator by sliding the shaft into the round hole of the right side frame and the left side into the hex shaped brake hub.
11. Remove top film supply roll from laminator. Repeat steps 7 and 8 from above ensuring the film will unroll from the bottom after the film supply shaft it is placed back on the laminator.
12. Unroll 2 ft. (61 cm) of film. Drape the film over the top idler bar and completely cover both heat rollers.
13. Slide the feed tray under the bottom film web that is draped over the bottom roll of film. Reinstall feed table so that the bottom film web is resting on the tray, (Figure 8).
14. Slide the threading card between the feed tray and the film web lying on the tray. Gently push into the nip area of the heat rollers. The card should now be guiding both rolls of film into the heat rollers, (Figure 9).
15. Lower safety shield then push **RUN** [▶]. Watch the leading edge of the threading card to ensure that it enters the nip area of the heat rollers and is being pulled into the laminator. Push **STOP** [⏹] once the threading card has exited the rear of the laminator.

16. Check the film alignment. See section **FILM ALIGNMENT PROCEDURE** for instructions if installed film needs alignment.



CAUTION THE FOLLOWING PROCEDURE IS PERFORMED WHILE THE LAMINATOR IS HOT. USE EXTREME CAUTION. AVOID CONTACT WITH THE HEAT ROLLERS.

Method For Tacking New Film to Existing Film

The following describes a method for loading film whereby the existing film present on the heat rollers may be used in place of the threading card to draw the new film through the laminator. The adhesive of the existing film must be tacky or liquefied. Leading edges of the new film will be overlapped onto the tacky adhesive of the old film. The existing film and the new film will be pulled through the laminator together.

1. Preheat the laminator. Remove the feed tray.
2. Cut remaining top and bottom film webs between the supply rolls and heat rollers.
3. Raise safety shield to full upright position.
4. Do not allow the adhesive side of the film to contact the heat or pull rollers. Liquefied or tacky adhesive deposited on heat rollers will require the rollers to be cleaned per the section **CARING FOR THE ULTIMA 65 LAMINATOR**.
5. Remove bottom film supply roll from laminator, lower bottom film guide.
6. To load new film on film supply shafts repeat steps 7 and 8 in subsection **Method Using Threading Card**.
7. Unroll enough film from the bottom roll of film to slide under the bottom idler bar and tack to the existing film. Slide the bottom idler bar back into place and replace supply roll shaft.
8. Replace the top supply roll shaft and unroll enough film to tack to the existing top roll of film.
9. Install feed table and lower safety shield.
10. Press **SLOW** for slowest speed setting and press **RUN** [▶].
11. Observe the film being pulled through the laminator to assure that the remaining existing film and the new film are advancing concurrently. Any separation between the films will require stopping the motor immediately and the situation corrected.
12. Press **STOP** [⏹] once the newly threaded film is completely exiting the laminator.

FILM ALIGNMENT PROCEDURE

The film supply shafts of the Ultima 65 Laminator come with pre alignment holes on the right side for 9"(21 cm), 12"(31 cm), 18"(46 cm) and 25"(64 cm) film widths. Loosen the locking screw on the right side retaining collar and move to the corresponding hole to match the width of your roll of film. Tighten the locking screw in the pre drilled hole.

FILM TENSION ADJUSTMENT



Proper film tension, known as brake tension, is the minimum amount of tension required to eliminate wrinkles in the finished item. The film tension is set at the factory. Periodic adjustments should not be necessary unless other than 1.0 or 1.5 mil GBC film is used or the lamination is curling up or down. Film tension may be checked occasionally to assure that the adjustment is not required.

The film should be taut. A properly adjusted roll of film should not require excessive force to turn by hand. Film tension should be enough to introduce a minor amount of drag as the film unrolls. Insufficient tension causes wrinkles while too much tension causes stretching (necking). Uneven tension between the top and bottom rolls create curl. Too much upper tension creates upward curl while too much bottom tension causes downward curl.

1. To adjust the bottom brake. Push and hold the brake lever, (Figure 11), located on the left side frame by the roll of film. Rotate the roll of film until the lever engages the internal mechanism.
2. Refer to Figure 10 for the proper rotation of the film to increase or decrease the tension.
3. Release the brake lever and check the tension by rotating the roll of film. Resistance should be slight, not forced.
4. To adjust the top brake repeat steps 1 through 3.
5. Laminate some test samples to check for proper tension. Further adjust if necessary.

CLEARING A FILM JAM (Wrap-up)

Film jams (wrap-up) may occur if the film is loaded on backwards or if the area at which film exits the equipment is blocked. The film, when jammed, wraps around heat or pull rollers. To clear a jam it is necessary to rotate the rollers in the reverse direction. When pressed, **REVERSE**  on the control panel will cause the rollers to go in reverse. To clear a jam:

1. Immediately stop the laminator by pressing **STOP** .
2. Set the speed indicator to 2.
3. Raise the safety shield and remove the feed tray.
4. Cut the top and bottom film webs.
5. Grasp the loose ends of the web, pull straight out, install the feed tray so the web is on top of the tray. Lower the safety shield, press **REVERSE**  and guide the film out of the heat rollers.
6. Once the jam has cleared the heat rollers press **STOP** .
7. Thread the film per section FILM LOADING & THREADING.

SPEED GUIDE AND THE ART OF LAMINATION

Do not attempt to laminate abrasive or metal objects such as staples, paper clips and glitter as they may damage the heat or pull rollers.



Do not force items into the nip area of the heat rollers. An item that is not easily drawn into the laminator by the heat rollers is probably too thick to laminate.

Wrinkles may result if an attempt is made to reposition an item once it has been grasped by the heat rollers.

Do not stop the laminator before an item has completely exited the pull rollers. Even a momentary stop will cause a mark (heat line) on the laminated item.

Good, consistent lamination is a result of combining proper heat, tension and dwell time. Dwell time is the amount of time the material to be laminated is compressed between the heat rollers and is control by the speed control. When one of the film gauge buttons is selected the laminator automatically sets the speed and temperature for that film and 20 lb. paper.

As a general rule thicker items and films as well as dark or full ink coverage, need to run at slower speeds because they extract more heat from the rollers at a quicker rate. Setting the speed control at slower settings gives the laminator longer dwell time thus allowing proper lamination of thick items. Thinner items, such as standard copier paper (20 lb. bond) and tissue paper, extract less heat from the rollers and can be run at faster speeds.

The **WAIT**  lamp may illuminate if the speed is set too fast for the material being laminated. Either lower the speed setting or press **STOP**  and wait until the **READY**  lamp illuminates.

Operation of the laminator for more than thirty minutes at a time may necessitate a lower speed setting. It is recommended that during periods of long runs the items being laminated are alternated between thick and thin. **Do not combine thick and thin items at the same time as this will result in a poor edge seal around the thinner material.** If you are unsure that the laminator is set at the proper speed for your item, run a test piece (scrap) of the same or similar material through the laminator. This procedure is recommend because rotating the heat rollers prior to lamination will more evenly distribute the heat. Make speed adjustments as necessary.

The following chart provides general guidelines for proper speed settings to use on certain materials and laminating film combinations. **This chart is only a general guide. Different settings may become necessary as the warm up time, lamination time and materials change.**

Material	SPEED GUIDE		
	Film Thickness		
	1.0 Mil (.0010")	1.5 Mil (.0015")	3.0 Mil (.0030")
Newspaper			
20 lb. Copier Paper	8 - 10	8 - 10	3 - 4
Magazine Stock			
Tissue Stock			
Construction Paper	5	5	1 - 3
Posters			
Index Cards			
File Folders	1 - 3	1 - 3	1 - 2
Poster Boards			

CARING FOR THE GBC ULTIMA 65 LAMINATOR

GBC offers Cleaning kits as well as Extended Maintenance Agreements.

Contact your local GBC Service Representative or your dealer/distributor additional information.

The only maintenance required by the operator is to periodically clean the heat rollers. The following procedure will help keep the heat rollers free of adhesive that has been deposited along the edge of the laminating film. Proper alignment of the rolls of film reduces the amount of "squeeze out".



CAUTION: THE FOLLOWING PROCEDURE IS PERFORMED WHILE THE LAMINATOR IS HOT. USE EXTREME CAUTION.





WARNING: Do not apply cleaning fluids or solvents to the rollers.



WARNING: Do not attempt to laminate adhesives marked "Flammable".

- NEVER clean rollers with sharp or pointed objects.
- Hardened adhesive deposits on the rollers can cause damage to the rollers. Rotate the rollers at the lowest speed setting on the control panel.
- Do not laminate glitter and/or metallic items. Damage to the rollers may result.

1. Remove the film from the laminator following the procedure outlined in the section FILM LOADING AND THREADING.
2. Preheat the laminator until the **READY**  lamp illuminates.
3. Rub the top and bottom heat rollers with a 3M™ Scotch-Brite™ pad.
4. Install the feed table and lower the shield.
5. Press **RUN**  to rotate the heat rollers to an unclean portion. Press **STOP** . Continue this process until the complete surface of both rollers are clean.
6. Follow the procedure in section FILM LOADING AND THREADING, **Method Using Film Threading Card** to reload the laminator.

***NOTE:** Do not use metal scouring pads to clean rollers!

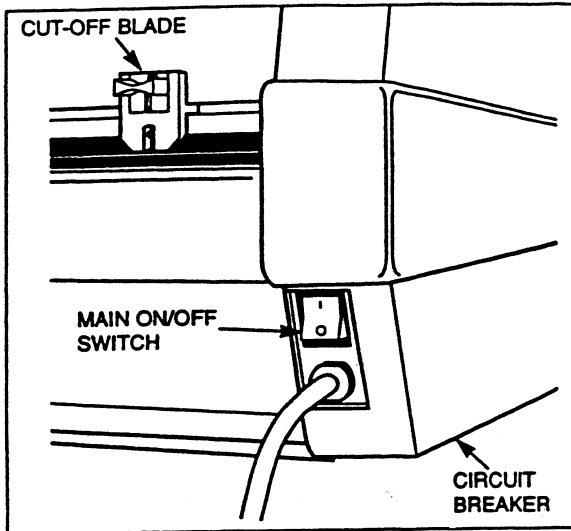

Fig. 1

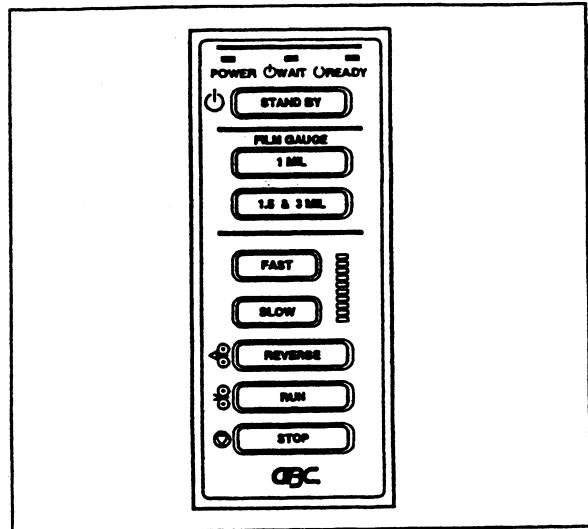

Fig. 2

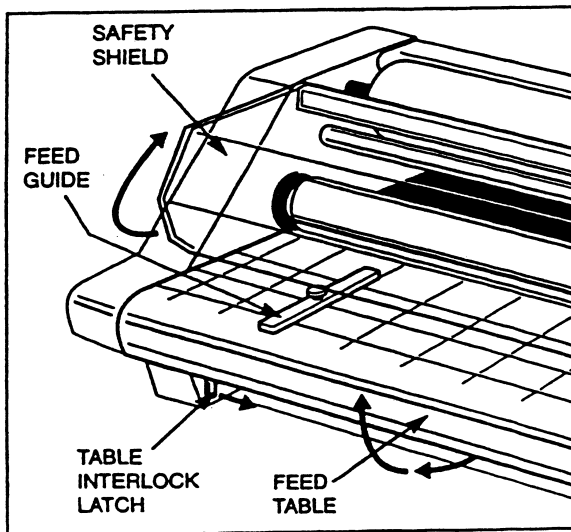

Fig. 3

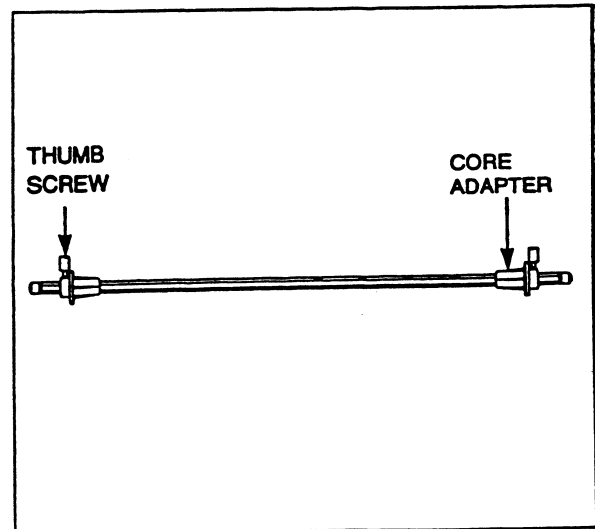

Fig. 4

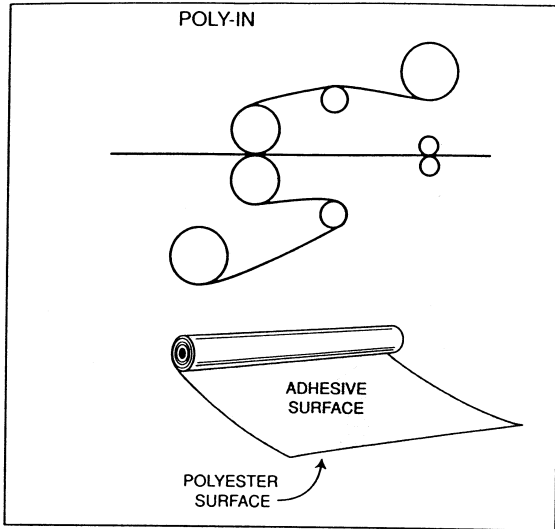

Fig. 5

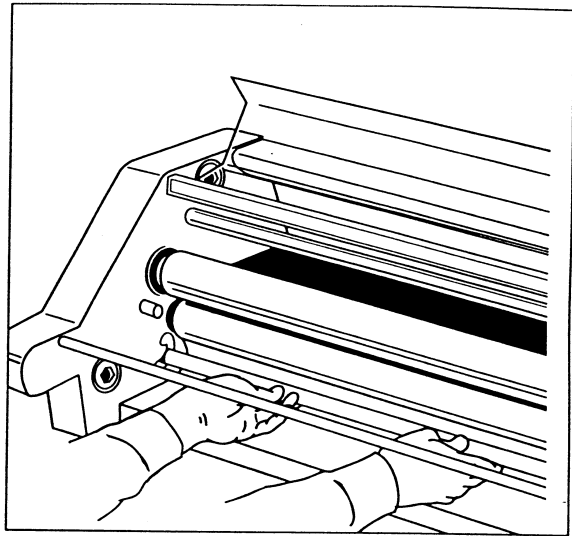

Fig. 6

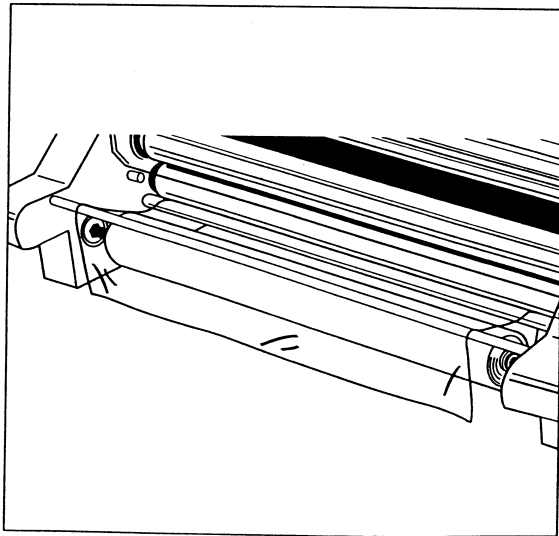

Fig. 7

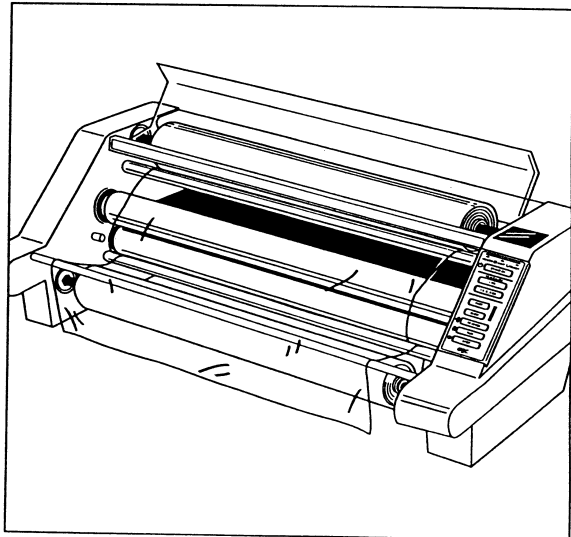

Fig. 8

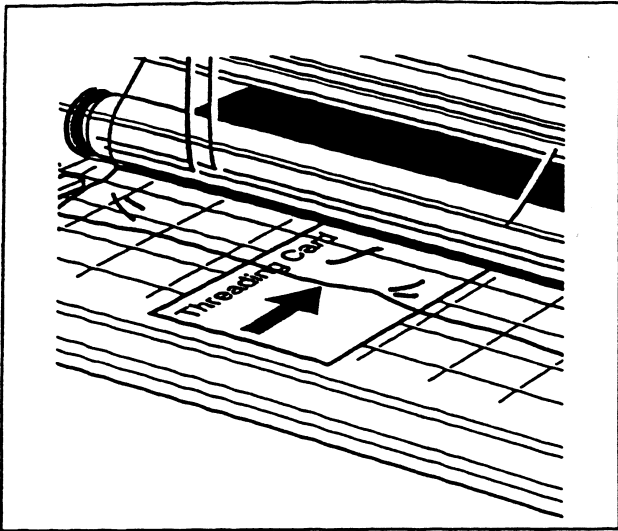

Fig. 9

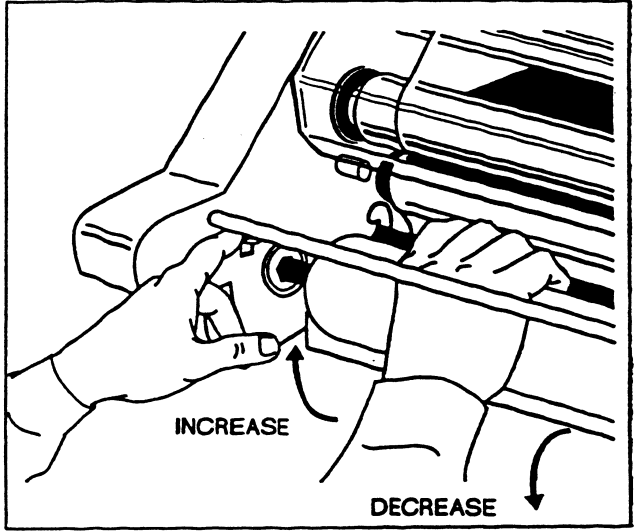

Fig. 10

